

HS-1600A Technical Data Sheet

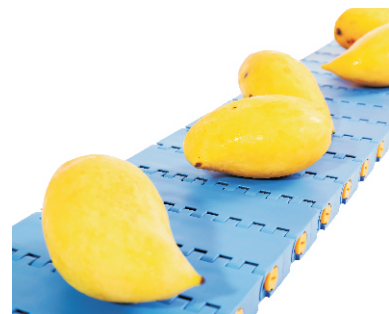
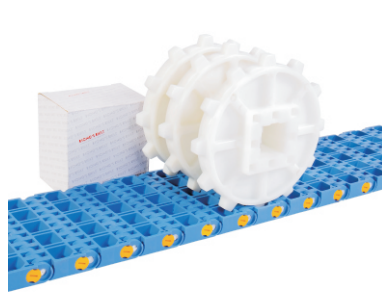
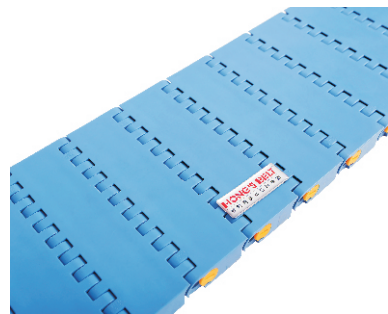
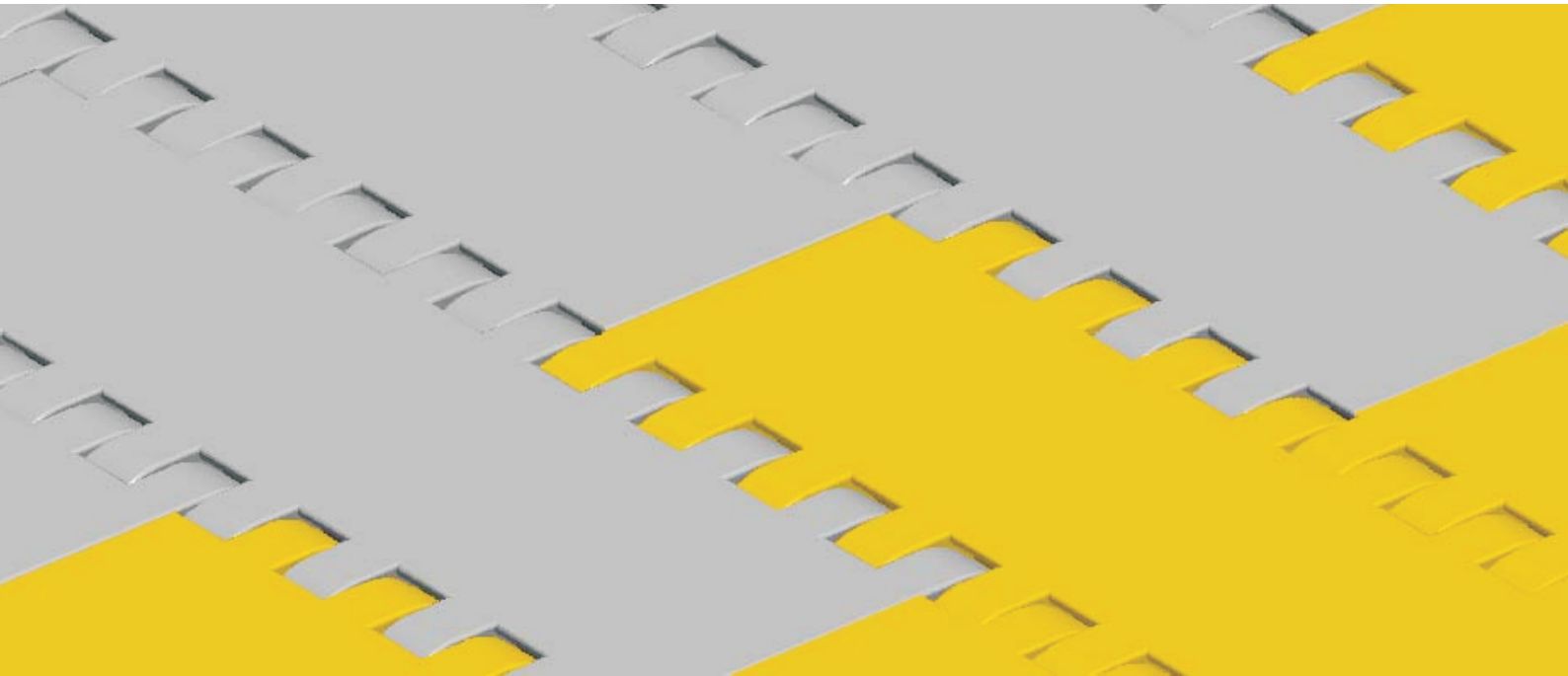

Pitch: 50.8mm Minimum Width: 163mm Open Area: 0% Approved: FDA Rod: Ø 8.0mm Flight: No Side Guard: No Curve: No	
--	--

Data

Belt Material	Belt Strength			Temperature		Belt Weight (Kg/M ²)
	Straight		Curve	°C (min.)	°C (max.)	
	Kg/M(BW)	N/M(BW)				
PP+ AS	3000	30000	--	1	104	15.0
Acetal	5000	50000	--	-40	80	21.3
Acetal+ AS	5000	50000	--	-40	90	21.3

BW – Belt Width AS –Anti-Static

Color Table

Polypropylene					Polyethylene					Acetal					Nylon				
W	G	N	DB	B	W	G	N	DB	B	W	G	N	DB	B	W	G	N	DB	B
●	●									●				●					

W-White,G-Gray,N-Nature,DB-Darkbrown, B-Blue

Friction Table

Belt Material	Friction Wear strips & Products							
	UHMW	HDPE	Steel	Glass	SUS	Plastic	Cardboard	Aluminum
Polypropylene	0.32	0.24	0.15	0.09	0.13	0.08	0.15	0.25
Polyethylene	0.13	0.11	0.26	0.19	0.31	0.16	0.21	0.41
Acetal	0.11	0.09	0.27	0.16	0.26	0.15	0.19	0.28
Nylon	0.18	0.13	0.25	0.16	0.26	0.16	0.19	0.27

SUS – Stainless Steel

Equivalent type with other Brand

Brand Name	Intralox	UNI	Rexnord	MCC	Habasit	KVP
Series & Type	200	CPB C	6390	2000	HDS620	
	800		2010			
	850		2000			

The above content is only for reference.

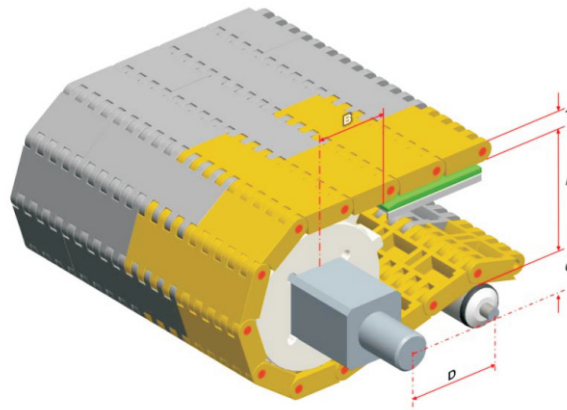

Conveyor Frame Dimensions

Unit : mm

No. Teeth	A (Min.)	B (Min.)	C (Max.)	D (Min.)	T
12	87.25	107.25	81.25	300	20
15	111.75	131.75	105.75	300	
18	136.5	156.5	130.5	300	

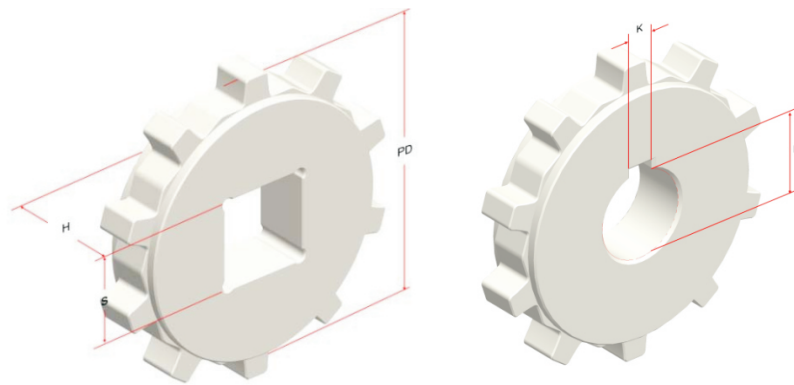

Sprocket Dimensions

Unit: mm

No. Teeth	PD	S	D	H	K
12	194.5	38.5/40.2/60.5	--	45	--
15	243.5	60.5	--	45	--
18	293	90.5	--	45	--

⌘ The above sprockets are standard, and it also can be customized according to customer's request, including the teeth number of sprocket and the size of square bore; the processing time is about 2 weeks.